

AP&T[®]

Shanghai Anping Static Technology Co.,Ltd

New Product

Intelligent Control | Network
Ionizing Air Blower



—AP&T—

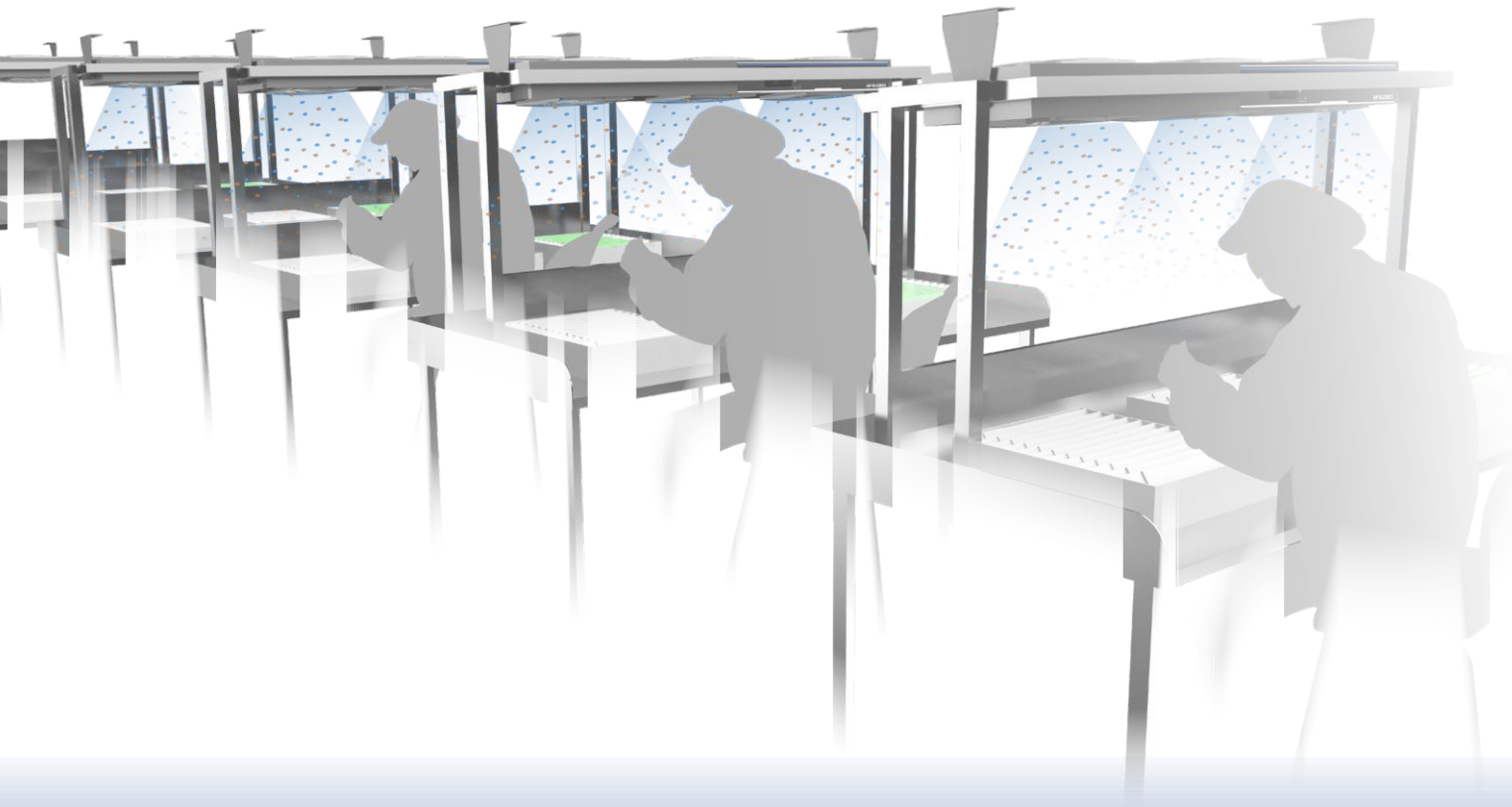

Suitable for electronics, optoelectronics,
semiconductor and other industries

Effectively solve the problems
caused by static electricity



Static removal

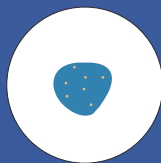

Prevent adhesion of objects

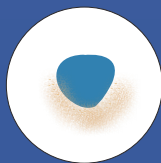

Prevent material splash

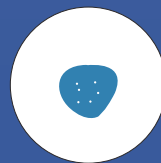

Prevent static electricity

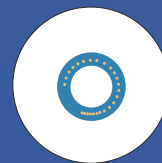

Prevent blockage of feeder

Intelligent Networking

Multiple networking methods to monitor the working status of ionizing air blower online

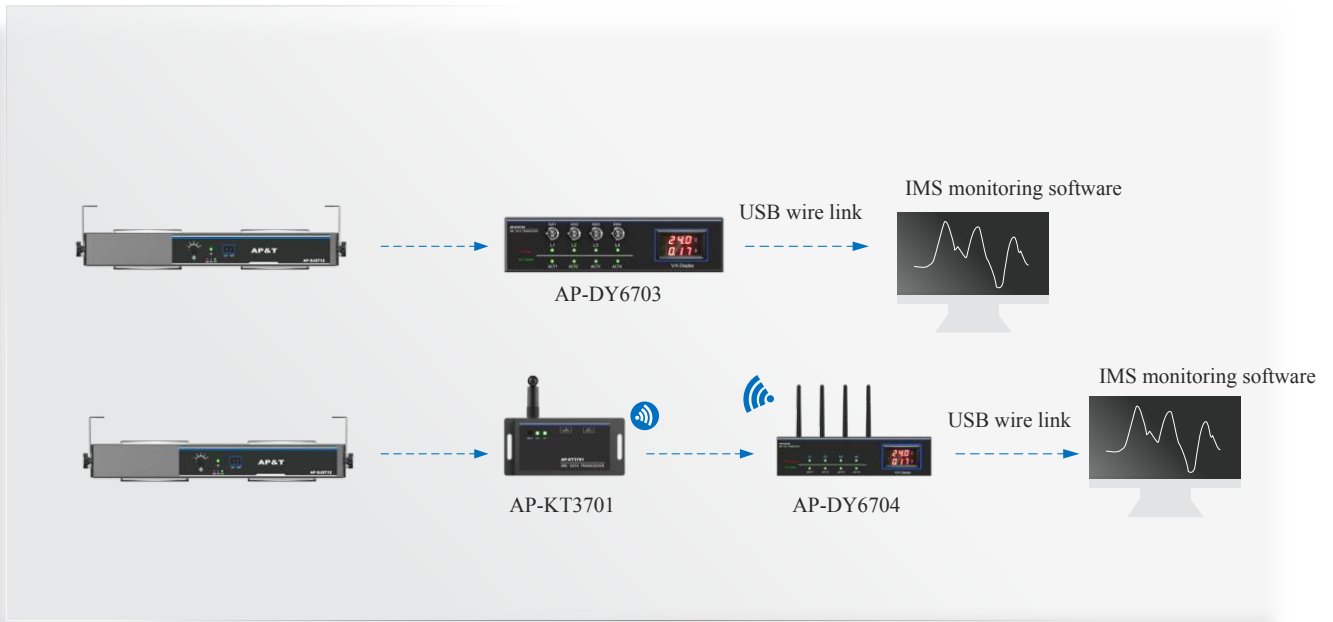
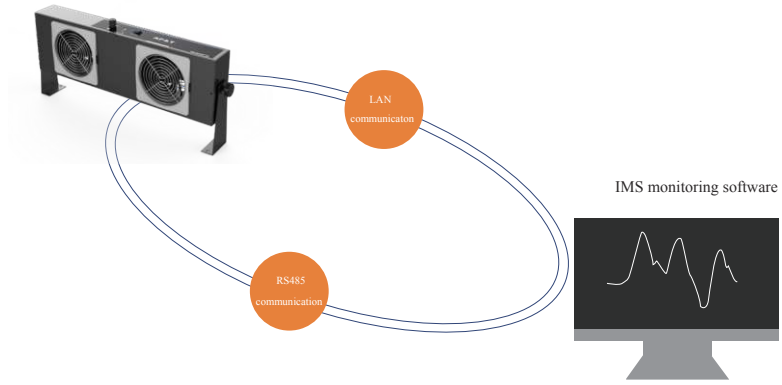

Intelligent Remote Control

Cleaning time /Air volume output adjustable



Cleaning time setting

Set a reminder for the cleaning time at will. Blue light flashes indicates cleaning is required. The electrode needle cleaning cycle should be set according to the working environment when using the ionizing air blower. Cleaning cycle should be shorten appropriately in environment with more moisture and dust.

Air volume output adjustable

Fan speed in five gears. Adjust the air volume according to the installation distance of the static eliminator and the status of the target object.

Duty ratio adjustable

Press PWM first, then press - to reduce the duty ratio of the positive high voltage output when the positive voltage on flat panel detector or discharge object surface is high, press PWM first, then press + to increase the duty ratio of the positive high voltage output when the negative voltage on flat panel detector or discharge object surface is high until the ion balance reaches the ideal status. Static electricity removing speed can be increased by adjusting the output ratio of positive and negative ions.

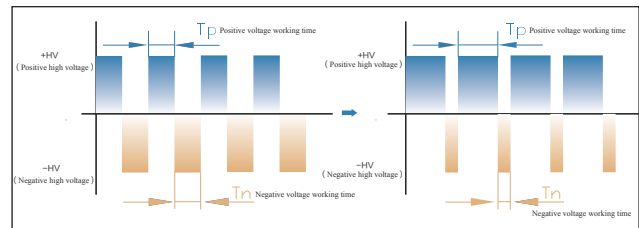

Button Function instructions

Function	Symbol	Operation instructions
Unlock		Unlock before adjusting operating parameters; 30s delay if any key is pressed, exit and re-locked if no key is pressed.
Run / Pause		Device starts running when power is on. Press "STOP" to standby and no high voltage output. Press "RUN" again and the device will start working.
Clean		Press the button to clean the needle once.
Adjust clean time	CT _{TH} → +/-	Press CT _{TH} first, and then press +/- to increase or decrease the cleaning cycle. Minimum adjustment unit 1H.
Adjust air volume	CFM → +/-	Press CFM first, then press +/-, air volume from high to low is 1,2,3,4,5.
Adjust duty ratio (Ion balance)	PWM → +/-	Press PWM, then press +/- to increase or decrease the duty ratio of positive high voltage output.
Confirm	CAL → OK	Note: Press CAL first, then press OK to confirm after adjusting the output parameter.
Reset	CAL →	Reset (8H), Press CAL first, then press

Press PWM first, then press - when the positive voltage on flat panel detector or discharge object surface is high, press PWM first, then press + when the negative voltage on flat panel detector or discharge object surface is high until the ion balance reaches the ideal status.

DC

The discharge effect is better compared to the high frequency AC ionizing air blower

DC VS High frequency AC

DC method generate ions with two polarity by applying "+" and "-" high voltage on two electrode needles. The utilization rate of ion generation is high, the external electromagnetic interference is small and the pollution degree of the particulate matter in the purification environment is small.

Currently many ionizing air blowers in the market adopts high frequency AC. Due to the low discharge voltage and weak electric field, the dust resistance is poor, which is easy to cause corona occlusion and unable to eliminate static electricity.

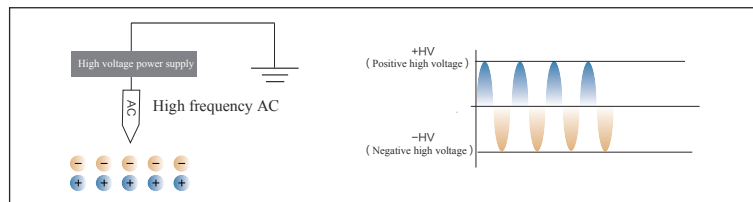
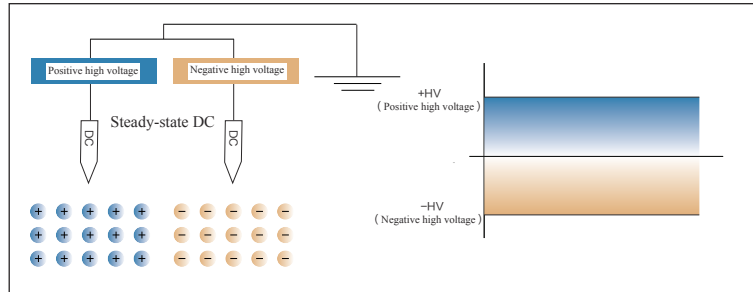

High Efficiency Static Removal

Keep a clean production environment and stay away from static electricity

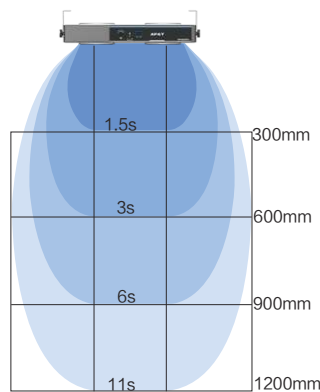

Test standard: ANSI/ESD.STM3.1, SJ/T 11446—2013
Test instrument: Trek 157 charge plate tester
Test voltage: $\pm 1000V \rightarrow \pm 100V$ attenuation
Test environment: humidity 50 \pm 5%; temperature 23 \pm 3 $^{\circ}C$

Discharging time: Discharge speed within 3 sec when distance is 450mm.

Discharging range: Up to 550mm width

Features

Safe / Easy to use / Durable



No.1

Magnetic net cover

The power is cut off immediately when the net cover is separated, which is convenient for disassembly and maintenance.

No.2

4 Electrode needles

4 tungsten electrode needles with longer life time. High speed 7-blade fan transfers larger ion air volume.

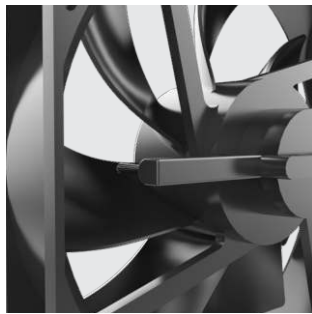

No.3

Built-in cleaning brush

The ionizing air blower automatically brush the needle after it is turned on. During operation, the ionizing air blower automatically brushes the needle every 8 hours without manual brush cleaning and maintenance.

No.4

Visualization of working status

Red light alarm: Ionizing air blower break down or abnormal high voltage.

Blue light flashing: Debugging or cleaning

Green light on: Ionizing air blower is working normally.



Features

Safe / Easy to use / Durable

No.5

Intelligent remote control

The output ratio of positive and negative ions is adjustable, which can be used to adjust the ion balance voltage.

Ion output characteristics can be adjusted by remote control.



No.6

CE certification

CE certified with electromagnetic protection function and no electromagnetic interference to other equipment. It can also effectively avoid external electromagnetic interference affecting the normal operation of the air blower.

No.7

Five speed adjustment

High air volume fan five speed control with stable performance. Air volume output 1.45 times higher than ordinary fans.

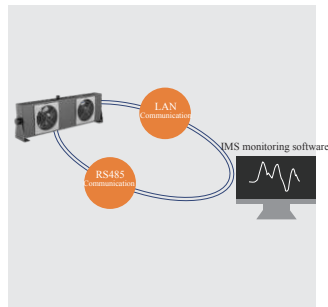
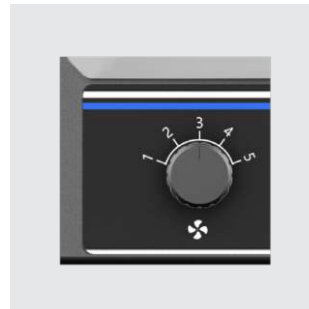

No.8

Network Monitoring

Wired network communication realisable and monitor the working status of the air blower.

Product Specifications

Details/specification/dimensions

Details

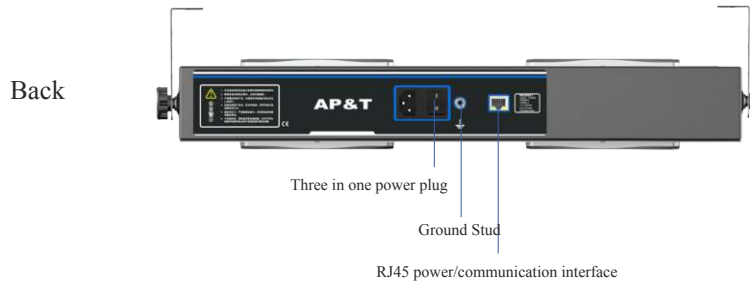
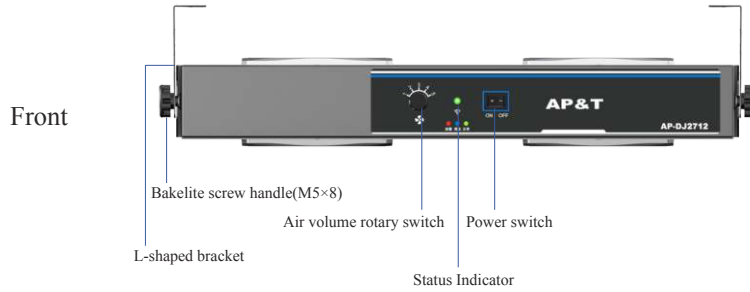

Power interface cable function information		
1、 2	Orange /White-orange	VCC: +24VDC
3	Blue	RS485+B
4	White-blue	RS485+A
5	Green	GND
6	White-green	GND
7	Brown	VTH: Sensor threshold alarm HVAL: Eliminator high voltage alarm
8	White-brown	ACT: Sensor/eliminator power-on indication Clean: Eliminator cleaning indication
9	Metal shield	PE

Specification

Model	AP-DJ2712
Input voltage	DC 24V (RJ45 interface) / Three in one socket (220VAC 50/60Hz)
Input Current	< 0.15A AC
Output voltage	DC±4KV → ±7KV
Power	< 33W
Ion emission	DC
Emitter electrode	Tungsten alloy
Discharge range	750*550mm (L*W)
Air volume	≤ 135CFM*2
Noise	Single air outlet≤ 58dBA (1000mm away from the air outlet)
Ozone thickness	≤ 0.05ppm (150mm away from the air outlet)
Ion balance	≤ ±15V
Discharge speed	≤ 3S (450mm directly below the air outlet)
Alarm indication	Power on/clean operation—blue light flashes;
	Normal work—green light (always under monitoring status);
	Fan alarm—red light always on;
	High voltage abnormality—red light flashes;
	Blue light flashes during infrared debugging
Communication method	RS485
Working temperature	0°C -50°C
Working humidity	< 70%RH
Dimensions (L*W*H)	535*154*67mm (Ionizing Air Blower body size)
Shell material	Aluminum powder spraying
Installation accessories	1 pair of L-shaped iron powder spraying mounting brackets, 1 pair of bakelite screw handles (M5×8)
Power adapter	INPUT: AC100—240V 50/60Hz;
	OUTPUT: DC24V 2A (dual RJ45 interface)
Net weight(Including power cord and bracket)	3.2KG
Gross weight	3.5KG
Warranty	1 Year
Certification	CE

Dimensions

Unit: mm

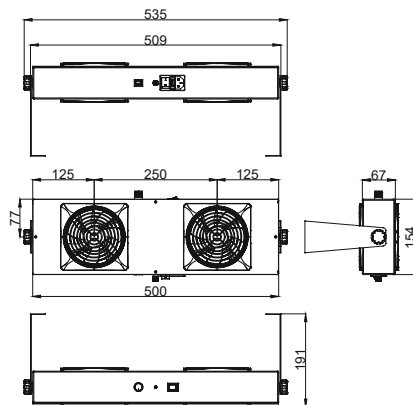

Installation accessories:

1 pair of L-shaped iron powder spraying mounting brackets.
1 pair of bakelite screw handles (M5×8) .

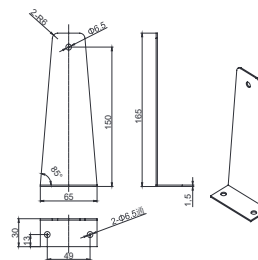

Products Use

Installation steps/technical tips/Installation accessories

Installation steps

1. Install the ionizing air blower and the matching power adapter firmly in the best discharge position.
2. Insert the circular plug of the power cord of the adapter into the power socket of the ionizing air blower and the three-core power socket into the row socket.
3. Touch the power switch on the front panel of ionizing air blower. It will automatically brush the needle after starting and the fan works normally when the indicator light is green.

Technical tips



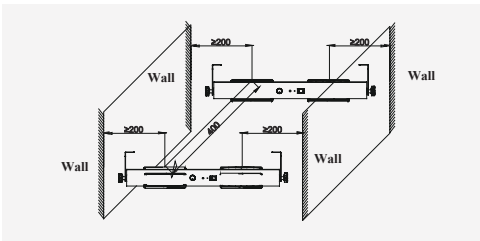

1. Place the ionizing air blower in the work area where static electricity is to be eliminated and the installation angle is perpendicular to the surface of the charged body.
2. Ionizing air blower should be at least 300mm away from the metal conductor and metal grounding body. The ionizing air blower must be reliably connected to the ground wire.
3. Two ionizing air blowers should be installed side by side with an interval of more than 400mm and more than 200mm away from obstacles such as walls.

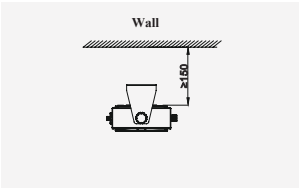

4. The air inlet is at least 150mm away from the wall and the bracket installation angle can be manually adjusted.



Packing accessories

Part name	Picture	Part No.	Specification	Q'TY
Power adapter		OSP000601	GRT-240200: DC24V 2A, Dual-port output, size: 123*61*40.5mm (L*W*H)	1
National standard power cord		8YXG25110	Standard 1.8m, Optional 3m/5m	1
Power cable		8WXI00004	Standard 2.5m, Optional 5m/10m	1
Remote control		AP2253011	IR remote control neutral, 84×38mm	1

▲ Safety warning

1. Please read the instruction manual carefully before installing and using this equipment.
2. The whole set of equipment must be reliably grounded during use, and the connection resistance of the electrical connection to the AC equipment ground should be less than 1 ohm.
3. Do not use this equipment in environment where humidity is > 70%.
4. It is strictly forbidden to use this equipment in flammable and explosive environments.
5. Unauthorized disassembly of the product is strictly prohibited, internal maintenance and repair must be performed by professionals.
6. The product is strictly prohibited to touch liquid during use, otherwise an abnormality may occur and cause electric shock or fire.
7. Power must be turned off during inspecting or replacing the product, otherwise it may cause electric shock or fire.
8. The product is specially designed to eliminate static electricity. It is strictly forbidden to use it for other purposes. Any abnormal use may cause machine failure, electric shock, fire and other accidents.
9. It is strictly forbidden to touch the electrode needles when power is on, otherwise it is easy to cause malfunctions and electric shock accidents.
10. The electrode needle is a sharp metal object, please use it with care.
11. Please check the specifications of the power supply before powering on the product. Any power supply that does not meet the specifications will cause damage to the product.
12. Please check the product power cord/communication cord regularly, and replace it immediately if it is damaged, otherwise it is easy to cause problems such as electric leakage, poor communication, and abnormal operation.

▲ Trouble shooting

NO	Faults	Reasons	Solutions
1	The indicator on the fan panel is off	Poor contact of the power cable	Check whether the power cable is in good condition and securely connected
		Power supply mismatch	Confirm the power supply specification (INPUT: 100—240VAC 50/60Hz; OUTPUT: 24VDC 2000mA)
2	The electrostatic removal performance decreased obviously.	Discharge needle is polluted and damaged	Clean or replace the discharge needle
		Ionizing air blower is set incorrectly	Confirm the best installation location
3	The electrostatic removal performance decreased	There are conductors or other ionizing air blower around	Remove (moving) conductors or other ionizing air blowers
4	High voltage/ion balance alarm (Panel indicator light flashes red)	Electromagnetic interference	Turn off the power switch / unplug the power cable, restart the ionizing air blower
		Abnormal discharge	Confirm whether the electrode needle is touching the metal conductor
		No power supply for high voltage module	Return to factory for maintenance
		High voltage module is damaged	Return to factory for maintenance
		Ion balance alarm	After cleaning the electrode and net cover, use the remote control to re-adjust
		The cleaning brush covers the electrode needle	Brush the needle manually with the remote control, or shut down and restart to keep the cleaning brush away from the electrode needle
5	Fan alarm (Panel indicator red light always on)	Fan fault	Return to factory for maintenance
		The fan power supply circuit is damaged	Return to factory for maintenance
6	Unable to discharge	High voltage module is damaged	Return to factory for maintenance
		Main-board chip is damaged	Return to factory for maintenance
		Poor grounding / chip damage caused by no grounding	Check the grounding of the ionizing air blower and plant equipment, and return to the factory for maintenance
7	The product is smoky or burnt	The high-voltage module is damaged or the insulation of the discharge bracket is damaged	Return to factory for maintenance

Maintenance

1. In order to ensure the good performance of the product, the fan should be cleaned and maintained in time according to the use environment and the required electrostatic protection requirements, that is, using electrostatic brush, dust-free cotton swab, dust-free cloth dipped in anhydrous alcohol to gently remove the dust on the electrode, discharge bracket, fan and metal mesh cover. Note:
 - A. Operation must be done 10 minutes after power cut off.
 - B. The cleaning cycle of the electrode needle should be set according to the working environment during use of the fan. It should be appropriately reduced in the environment with more humid and dusty.
 - C. The fan must be powered on after alcohol is completely volatilized after cleaning. No other organic solvent can be used to clean the fan.
 - D. The alloy electrode is a consumable product which is not included in the scope of warranty and will be charged for replacement when repairing.
2. Do not press or rotate the control buttons on the fan panel too hard; otherwise, the device will be permanently damaged.
3. If the working indicator light on the front panel of the fan is off or red, it should be stopped and repaired by professional maintenance personnel. It can be used only after the electrical performance index is normal.

After-sales service

AP-DJ2712 ionizing air blower has undergone rigorous testing and aging treatment before ex-work. Its performance has completely reached the relevant indicators marked in the usage instruction.

AP&T makes a commitment to the customer that any defective parts inspected by AP&T will be repaired or replaced free of charge within one year from the date of purchase. However, this commitment does not apply to:

1. The device is incorrectly used or installed.
2. Damage caused by negligence or accident during use.
3. Modified, disassembled or repaired by other service departments not authorized by Anping Company.

AP&T shall not be liable for any incorrect use of the products except for repair or replacement of parts as specified above.

AP&T®

AP&T

Professional electrostatic intelligent monitoring/analysis
and elimination solution provider

Speciality Creates Value

Shanghai Anping Static Technology Co.,Ltd

Tel : +86-21-64517676

Fax : +86-21-64517673

Postcode : 200233

Website : www.ap-static.com

Address : 3/F, Building 27, No.69, Guiqing Road, Shanghai, China

